

Rev No.	Description	Date	Name
A	New Part	05/05/2003	A.Vismara

D  
C  
B  
A

D  
C  
B  
A

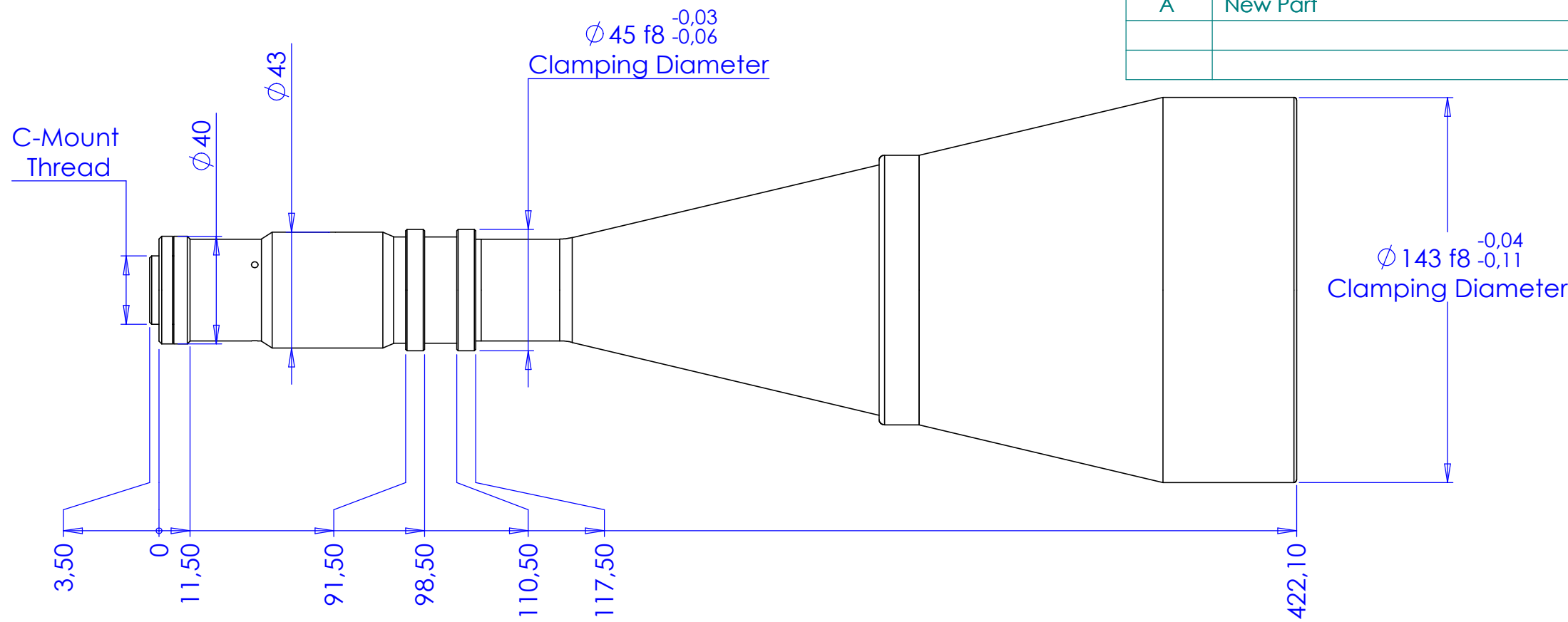

**TC 2M 96/C  
C-Mount**

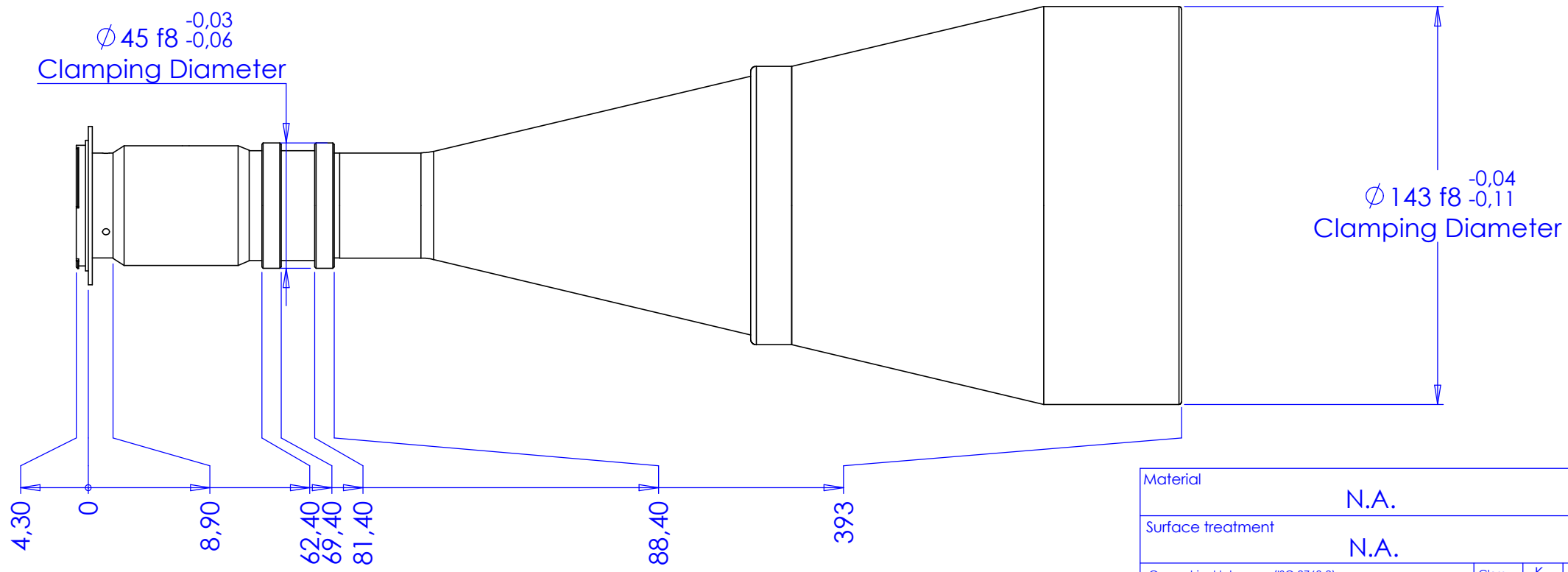

**TC 2M 96/F  
F-Mount**

Material	N.A.		Mass	2049 g	Scale	1:2																																																		
Surface treatment	N.A.		Project-Prod.item/Instrument TC 2M 96																																																					
Geometrical tolerance (ISO 2768-2)			Description Layout																																																					
<table border="1"> <thead> <tr> <th>Linear tolerance (ISO 2768-2)</th> <th>Class</th> <th>K</th> <th>Undimensioned bevels</th> <th>Undimensioned radii</th> </tr> </thead> <tbody> <tr> <td>0.5</td> <td>Class</td> <td>m</td> <td>0.5x45°</td> <td>R 0.5</td> </tr> <tr> <td>±3</td> <td>&gt;3±</td> <td>&gt;6±</td> <td></td> <td></td> </tr> <tr> <td></td> <td>6</td> <td>30</td> <td></td> <td></td> </tr> <tr> <td></td> <td>&gt;30±</td> <td>&gt;120</td> <td></td> <td></td> </tr> <tr> <td></td> <td>120</td> <td>±400</td> <td></td> <td></td> </tr> <tr> <td></td> <td>&gt;400±</td> <td>1000</td> <td></td> <td></td> </tr> <tr> <td></td> <td>±2000</td> <td>±4000</td> <td></td> <td></td> </tr> <tr> <td>±0.1</td> <td>±0.1</td> <td>±0.2</td> <td>±0.3</td> <td>±0.5</td> </tr> <tr> <td></td> <td>±0.8</td> <td>±1.2</td> <td>±2</td> <td></td> </tr> </tbody> </table>			Linear tolerance (ISO 2768-2)	Class	K	Undimensioned bevels	Undimensioned radii	0.5	Class	m	0.5x45°	R 0.5	±3	>3±	>6±				6	30				>30±	>120				120	±400				>400±	1000				±2000	±4000			±0.1	±0.1	±0.2	±0.3	±0.5		±0.8	±1.2	±2		Drawing No. 21589-0-A			
Linear tolerance (ISO 2768-2)	Class	K	Undimensioned bevels	Undimensioned radii																																																				
0.5	Class	m	0.5x45°	R 0.5																																																				
±3	>3±	>6±																																																						
	6	30																																																						
	>30±	>120																																																						
	120	±400																																																						
	>400±	1000																																																						
	±2000	±4000																																																						
±0.1	±0.1	±0.2	±0.3	±0.5																																																				
	±0.8	±1.2	±2																																																					
			Date	Name	Sheet																																																			
			Designed	17/07/2006	A.Vismara	1/1																																																		
			Draw	17/07/2006	A.Vismara																																																			
Checked			X	C. Sedazzari	Reproduction forbidden without specific authorization																																																			
OPTO ENGINEERING S.r.l. - 46100 Mantova Italy - Via Cremona, 29/2 - Tel. +39 0376 263525 - e-mai: info@opto-engineering.com - http://www.opto-engineering.com																																																								