

Rev No.	Description	Date	Name
A	Layout	17/09/12	

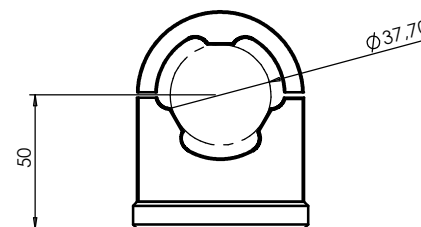
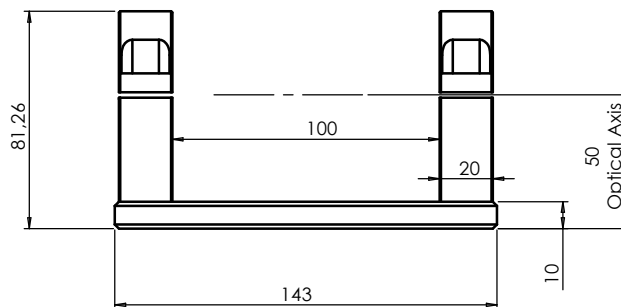
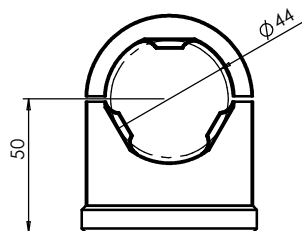
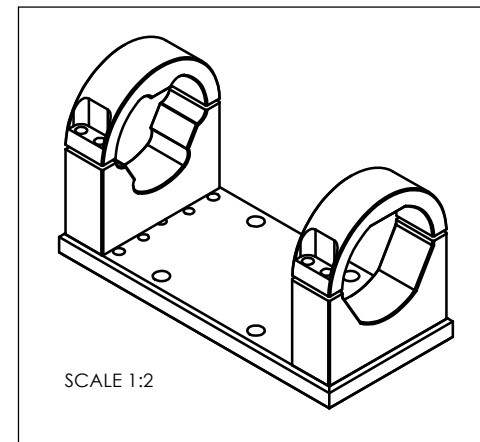
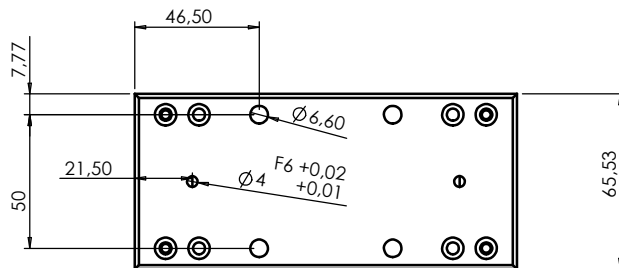

Material	N.A.			Mass	500 gr.	Scale	1:2
Surface treatment	N.A.			Project-Prod.item/Instrument		TC16M012	
Geometrical tolerance (ISO 2768-2)			Class	K	Undimensioned bevels		
Linear tolerance (ISO 2768-2)			Class	m	Undimensioned radii		
0.5	>3±	>6±	>30±	>120	>400±	>1000	>2000
±3	6	30	120	±400	1000	±2000	±4000
±0.1	±0.1	±0.2	±0.3	±0.5	±0.8	±1.2	±2
Date				Name			
Designed				17/09/12			
Draw				17/09/12			
Checked				X			
Description			Drawing No.		Sheet		
Clamp 16M012			20101-0-A		1/1		
Reproduction forbidden without specific authorization							
OPTO ENGINEERING S.r.l. - 46100 Mantova Italy - Via Cremona, 29/2 - Tel +39 0376 263525 - e-mat: info@opto-engineering.com - http://www.opto-engineering.com							