

Rev No.	Description	Date	Name
A	Nuova parte	02/02/10	N.Santini

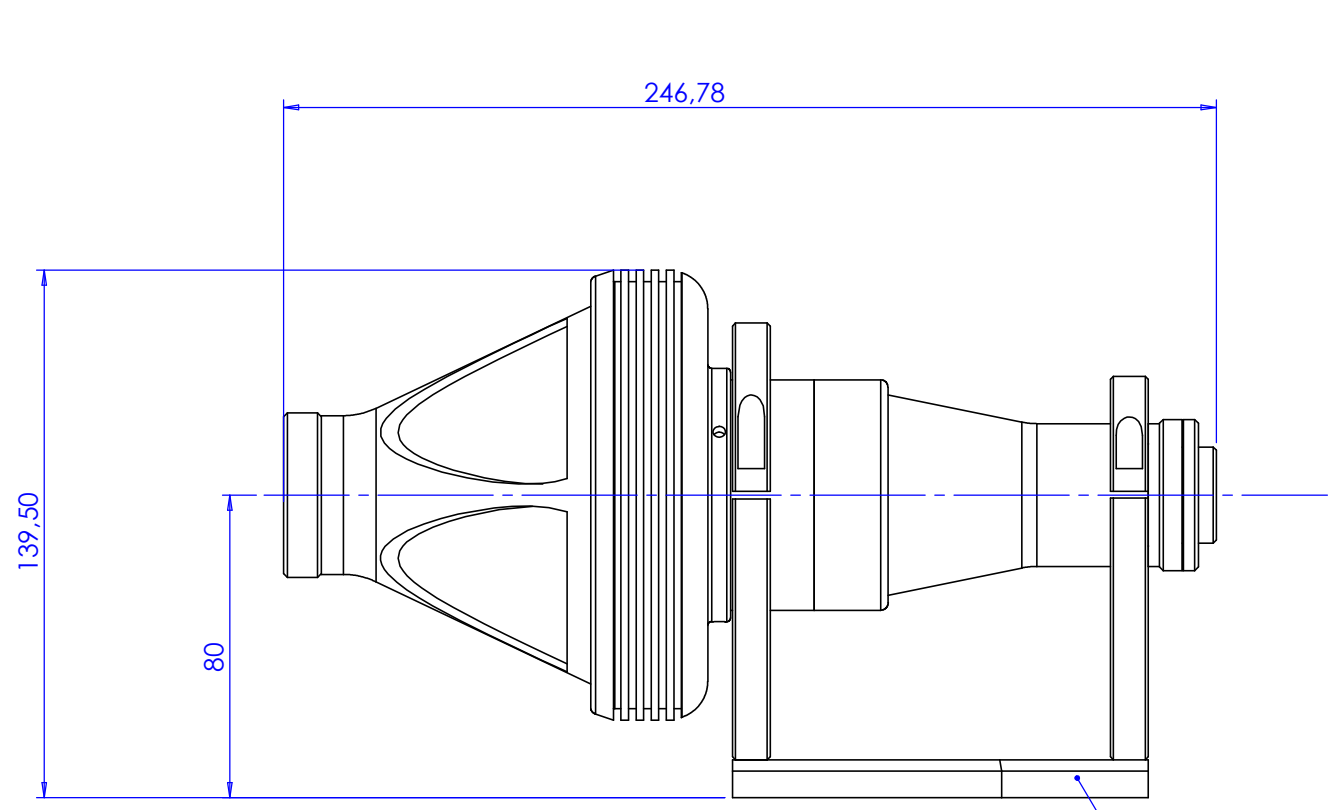

OE CMHO36

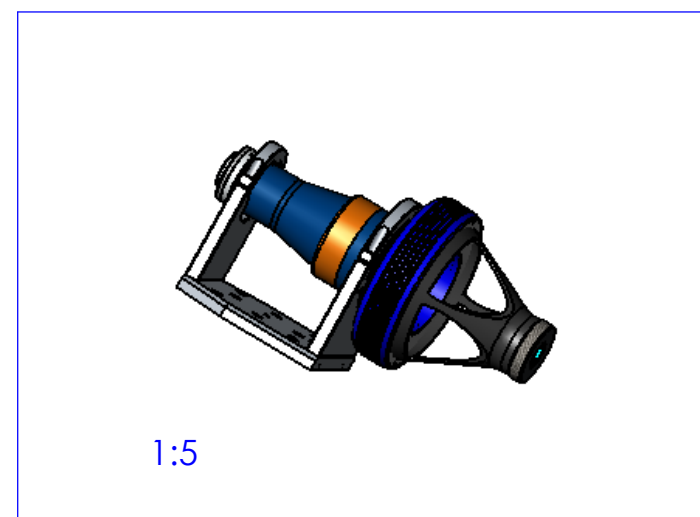
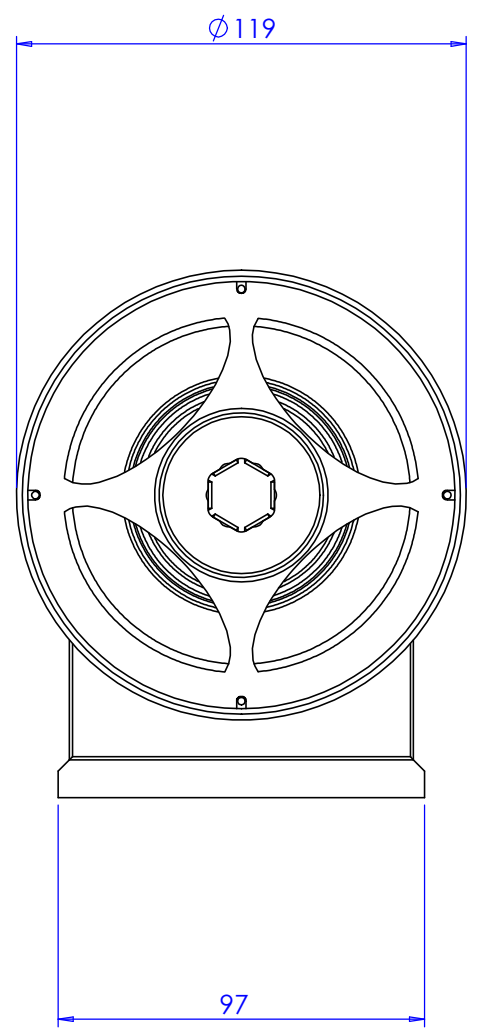

1:5

Material		N.A.		Mass		Scale		1:2	
Surface treatment		N.A.		Project-Prod.item/Instrument		PCMPXXY			
Geometrical tolerance (ISO 2768-2)				Class	K	Undimensioned bevels		1x45°	
Linear tolerance (ISO 2768-2)				Class	m	Undimensioned radii		R 0.5	
0.5 ±3	>3÷ 6	>6÷ 30	>30÷ 120	>120 ±400	>400÷ 1000	>1000 ±2000	>2000 ±4000	Description	
±0.1	±0.1	±0.2	±0.3	±0.5	±0.8	±1.2	±2	Layout PCMP012	
www.opto-engineering.com		Date		Name		Drawing No.		Sheet	
		Designed		N.Santini		19131-2-A		2/2	
		Draw		N.Santini					
		Checked		X					
Reproduction forbidden without specific authorization									