



Instructions manual

# LTDV1CH-7/LTDV1CH-17

Strobe controllers, 1 channel

## General index

1.	Disclaimer .....	3
2.	Safety notes.....	3
3.	General description.....	3
3.1.	Benefits of current control .....	4
3.2.	Pulsed mode .....	4
4.	Getting started .....	4
5.	Mechanical fixing.....	4
6.	Heat dissipation .....	4
6.1.	Calculating generated heat .....	5
6.2.	Reducing generated heat .....	5
7.	Connections .....	5
7.1.	Layout of connectors .....	6
7.2.	Power supply.....	7
7.3.	Lighting output.....	7
7.4.	Synchronization input and output .....	8
8.	Visual indicators.....	9
9.	Internal logic.....	9
9.1.	Diagram of internal logic .....	9
9.2.	Input filter .....	9
9.3.	Input multiplexer .....	10
9.4.	Output protection.....	10
9.5.	Free running oscillator .....	11
9.6.	Output pulse generator .....	11
10.	Wiring diagrams.....	14
10.1.	Wiring example #1 .....	14
10.2.	Wiring example #2 .....	15
11.	Operation .....	16

## 1. Disclaimer

Always deploy and store Opto Engineering products in the prescribed conditions in order to ensure proper functioning: failing to comply with the following conditions may shorten the product lifetime and/or result in malfunctioning, performance degradation or failure.

Ensure that incorrect functioning of this equipment cannot cause any dangerous situation or significant financial loss to occur. It is essential that the user ensures that the operation of the controller is suitable for their application. All trademarks mentioned herein belong to their respective owners.

Except as prohibited by law:

- All hardware, software and documentation is provided on an “as is” basis.
- Opto Engineering accepts no liability for consequential loss, of any kind.

Upon receiving your Opto Engineering product, visually examine the product for any damage during shipping. If the product is damaged upon receipt, please notify Opto Engineering immediately.

## 2. Safety notes

Please read the following notes before using this controller. Contact your distributor or dealer for any doubts or further advice.

This device must not be used in an application where its failure could cause a hazard to human health or damage to other equipment. Keep in mind that if the device is used in a manner not foreseen by the manufacturer, the protection provided by its circuits and by its enclosure may be impaired.

This is a low voltage device. As such, the potential difference between any combination of applied signals must not exceed, at all times, the supply voltage. Higher voltages may cause a fault and can be dangerous to human health.

This device has limited protection against transients caused by inductive loads. If necessary, use external protection devices like fast diodes or, better, specific transient protectors.

The controller outputs pulses with high energy content. The user must be careful to connect the inputs and outputs correctly and to protect the output wiring and load from unintentional short-circuits. When the device is switched off, there is still energy stored in the internal capacitors for at least 2 minutes.

When operating the controller at the maximum ratings it can get very hot. The controller should be positioned where personnel cannot accidentally touch it and away from flammable materials. Never exceed the power ratings stated in the manual.

## 3. General description

Any machine vision application employs some kind of light controller. Light controllers are widely used to both optimize illumination intensity and obtain repeatable trigger sequencing between lights and vision cameras.

This controller is a compact unit that includes power supply conditioning, intensity control, timing generation and advanced triggering functions.

The controller can be set up using the 4-way dip switch accessible from the top panel.

As usual symbol “s” is used to indicate seconds, “ms” for milliseconds and “μs” for microseconds.

### 3.1. Benefits of current control

Most LED manufacturers suggest their products to be driven using a constant current source, not a constant voltage source. This is because, using a constant voltage driving, small variations in temperature or voltage at the LEDs can cause a noticeable change in their brightness.

Brightness control with voltage is also very difficult because of the non-linearity of brightness with voltage. On the contrary, the brightness is approximately linear with current, so by driving the LEDs with a known current, intensity control is linear.

These strobe controllers have a single, fixed, constant-current pulsed output. For the LTDV1CH-7 model the nominal current is 7.5A, while for the LTDV1CH-17 model the nominal current is 17.0A.

### 3.2. Pulsed mode

This controller operates in pulsed mode. In this mode the lighting is switched on only when necessary. A digital input is used as a trigger. The output is turned on as long as the trigger signal is active.

Using this technique it is possible to obtain excellent steady images of moving objects. The camera can be set for an arbitrary long exposure time and the light turned on for a shorter time, just enough to freeze the motion. This helps to overcome the problems usually related with integration start uncertainty which, to some degree, afflict most commercial cameras.

## 4. Getting started

Carefully read the sections on Safety Notes and Heat Dissipation and check the product fits your needs. Mount the controller using a DIN rail as described in the section on Mechanical fixing.

Connect the controller as in the section on Connections. When the controller powers up it should show the PWR LED lit with a stable green.

Read the section on Operation. Use the 4-way dip switch to configure the unit.

## 5. Mechanical fixing

The controller must be mounted on a DIN rail. Allow free flow of air around the unit. The controller has an IP rating of 20 and should be installed so that moisture and dirt cannot enter it.

An enclosure may also be required for other parts of the system such as power supplies. That enclosure would provide both mechanical and environmental protection in industrial applications.

## 6. Heat dissipation

The controller includes a linear circuit to produce the constant current output. This means that it generates heat which needs to be dissipated. The operating temperature range is 0°C to 40°C.

The controller can be supplied from a 24V to 48V DC power source. Take care of the actual supply voltage when calculating the generated heat.

## 6.1. Calculating generated heat

For a switched output the heat generated is given by:

$$\text{Heat[W]} = \text{LightingCurrent[A]} * (\text{SupplyVoltage[V]} - \text{LightingVoltage[V]}) * \text{DutyCycle}$$

Where:

$$\text{SupplyVoltage} = 24\text{V to } 48\text{V (same as supply voltage)}$$

The duty cycle is given by:

$$\text{DutyCycle} = \text{PulseWidth[s]} * \text{TriggerFrequency[Hz]}$$

The term *LightingCurrent* stands for the nominal lighting current, while the term *LightingVoltage* is its corresponding lighting voltage. Both of them are stated in the lighting documentation.

## 6.2. Reducing generated heat

There are several ways to reduce the heat generated by the controller. The simplest would be to turn the light off when not needed. If the light is on only when necessary the generated heat can be drastically diminished. Another opportunity would be to reduce pulse width or output current, if permitted by the application.

Another strategy to reduce the generated heat would be to connect lights in series instead of parallel, if possible. If you have several lights connected in parallel then changing the arrangement to series will increase the voltage across them but also reduce the overall current.

With no air flow, the controller can approximately dissipate the following powers:

- 10W at 20°C ambient
- 9W at 30°C ambient
- 8W at 40°C ambient

No fan cooling is required if the generated heat is no greater than these limits.

## 7. Connections

Refer to product specifications for information on connection ratings. All connections are made via screw terminals on the top panel of the controller. Check all connections carefully before switching on the equipment.

The controller has a single 24V to 48V DC supply. This supply can be cut off at any time. It can be removed to protect the end user from photo-biological hazard and other hazardous situations that may happen during fault conditions.

### 7.1. Layout of connectors

The following diagram depicts all the controller connections. Connectors are identified by their designators (P1, P2 and P3).

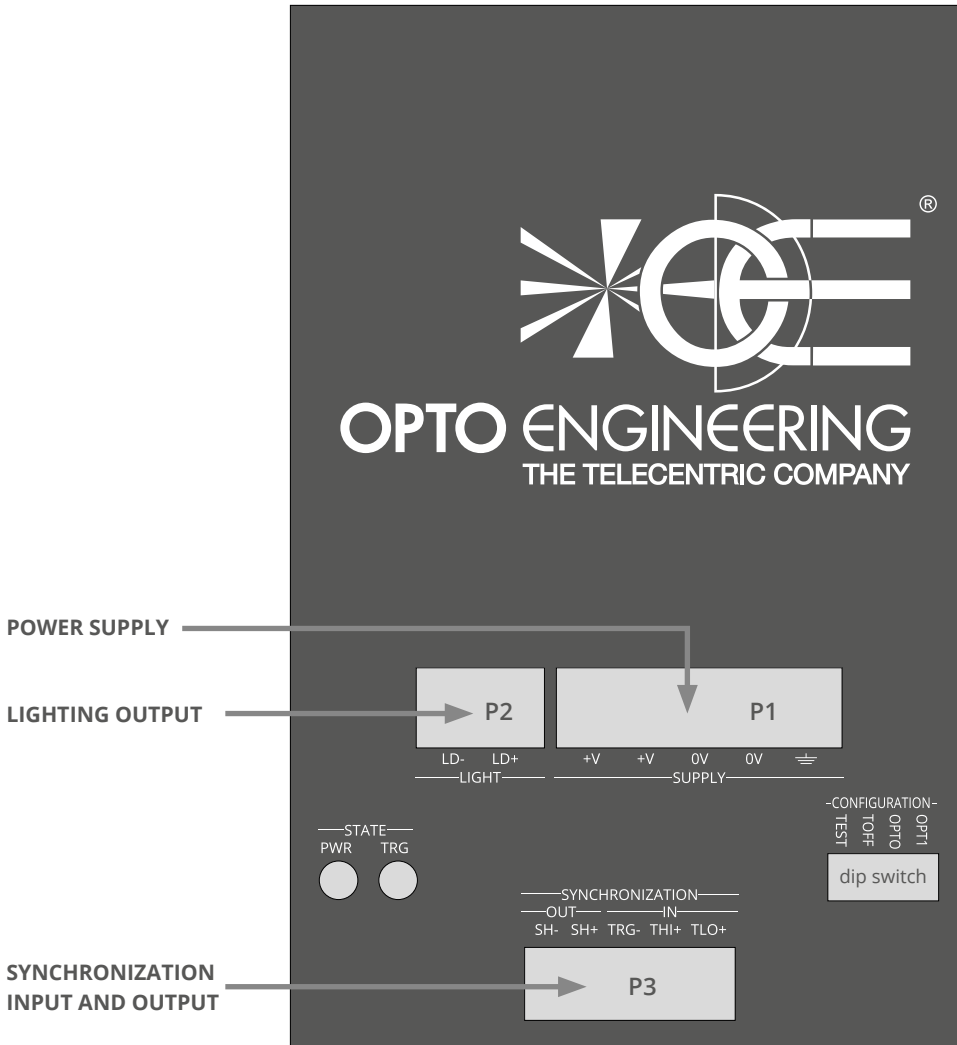

Illustration 1: connectors on the front panel

These connectors are all standard Phoenix Contact parts. For each one a mating plug is provided in the controller package; for convenience the relevant manufacturer part numbers are listed in the following table.

Connector designator	Manufacturer	Mating plug part number
P1	Phoenix Contact	1757048
P2	Phoenix Contact	1757019
P3	Phoenix Contact	1803604

Table 1: connector mating plugs

## 7.2. Power supply

A regulated 24V to 48V DC 3A supply is recommended. Maximum startup/inrush current is limited by an internal soft start feature to be no greater than 2.5A. The external power supply must be capable of supplying at least the average output power for the lighting.

Choose a power supply unit that limits its output current by design or use protecting fuses. The fuses should be appropriately de-rated if mounted in an enclosure, as the inside temperature can be higher than the ambient temperature.

Ensure that the wire gauge used for these power connections is appropriate for the current to be drawn. The low voltage and mains wiring should be separately routed.

The power supply is connected on the +V (positive) and 0V (negative) screw terminals of connector P1. Connector pinout, ordered from left to right, is listed in the following table.

Number	Name	Description	Note
1	+V	Power supply. Positive terminal	Pins have same potential. Use any
2	+V		
3	0V	Power supply. Negative terminal	Pins have same potential. Use any
4	0V		
5	Earth	Protection earth	

Table 2: pinout of connector P1

Ensure that the polarity of +V and 0V is correct.

## 7.3. Lighting output

The IEC standard 61010-1 defines an internationally recognised safe voltage level which can be touched by a user. A certain voltage is considered safe if, at all times, its peak value is no greater than 46.7V or its DC value is no greater than 70V.

According to the standard pulse peak voltages above 46.7V are considered hazardous to the human body. For this reason the lighting connections must be shielded from being touched along the whole length of the cable and in the light.

Make sure you use the right controller model for a light before connecting it. See the lighting datasheet and manual for details on this topic.

Light output is provided on a 2-way pluggable screw terminal socket. The lighting output connection must not be commoned or grounded in any way.

The state of the output is shown by the yellow TRG LED indicator.

Lighting output is connected on the LD+, and LD- screw terminals of connector P2. Connector pinout, ordered from left to right, is listed in the following table.

Number	Name	Description	Note
1	LD-	Power channel output. LED cathode	
2	LD+	Power channel output. LED anode	

Table 3: pinout of connector P2

Please note that LED- is not the same as 0V.

### 7.4. Synchronization input and output

There is a galvanically isolated synchronization input. This input can be connected directly to the system for voltages up to 24V DC. An external series resistor is not necessary.

There is a galvanically isolated synchronization output. This output can be used, for example, to trigger a camera or a slave lighting controller.

Synchronization input is connected on the THI+, TLO+ and TRG- screw terminals of connector P3, while synchronization output is connected on the SH+ and SH- screw terminals of the same connector.

Connector P3 pinout, ordered from left to right, is listed in the following table.

Number	Name	Description
1	SH-	Synchronization output. Emitter terminal
2	SH+	Synchronization output. Collector terminal
3	TRG-	Synchronization input. Negative terminal
4	THI+	Synchronization input. Positive terminal
5	TLO+	Synchronization input. Positive terminal

Table 4: pinout of connector P3

The following diagram depicts the internal circuit for the synchronization input. As visible in the diagram, two connections are feasible with those three wires: between THI+ and TRG- and between TLO+ and TRG-.

The constant current source connected in series with the TLO+ input allows for a broad range of input voltages without any need for a series resistor.

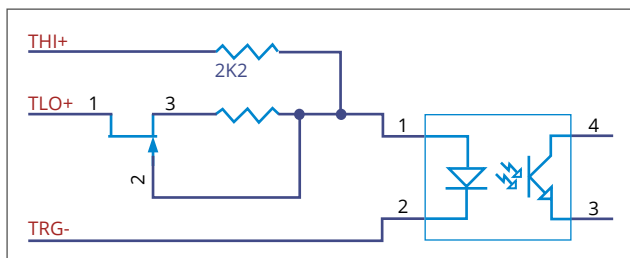

Illustration 2: input synchronization circuit

Circuit specifications of input synchronization circuit are summarized in the following two tables.

Parameter	Value	Unit	Note
Uin (low)	0-1	V	
Uin (high)	4-24	V	
Current (constant-current source)	6-8	mA	

Table 5: specifications of input synchronization circuit, connection to TLO+ and TRG-



Parameter	Value	Unit	Note
Uin (low)	0-10	V	
Uin (high)	20-24	V	
Current	8-12	mA	

Table 6: specifications of input synchronization circuit, connection to TH1+ and TRG-

The following diagram depicts the internal circuit for the synchronization output.

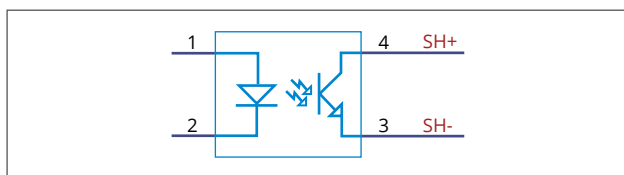

Illustration 3: output synchronization circuit

Circuit specifications of output synchronization circuit are summarized in the following table.

Parameter	Value	Unit	Note
I <sub>max</sub>	50	mA	
U <sub>max</sub>	30	V	

Table 7: specifications of output synchronization circuit

## 8. Visual indicators

There are two LEDs on the top panel of the controller. One of them is used to show that power supply is present, while the other is pulsed when the output is activated.

The exact meaning of each of the LEDs is listed in the following table.

Number	Name	Color	Description
1	PWR	Green	Stable when logic supply is present
2	TRG	Yellow	Pulses when lighting output is activated

Table 8: meaning of the LEDs

Please note power supply must be present in order for all the LEDs to turn on.

## 9. Internal logic

The controller has an internal digital logic to filter the synchronization input signal and to generate the synchronization output signal. An output protection circuit, used to prevent the lighting from getting overheated and thus damaged, is also included in this logic.

### 9.1. Diagram of internal logic

The following diagram depicts the logic network built in the controller.

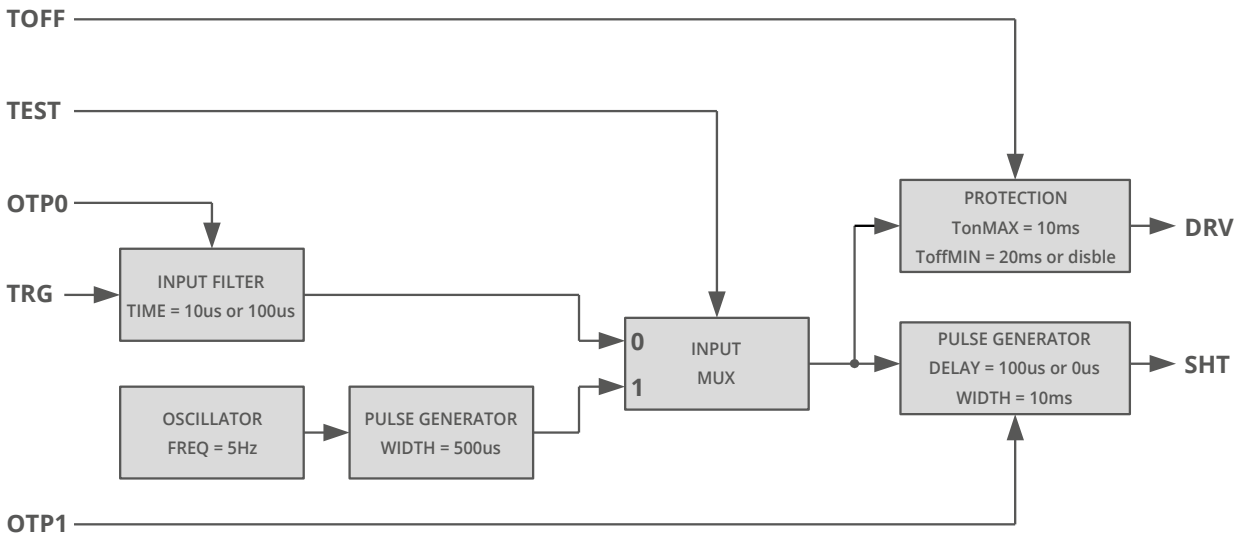
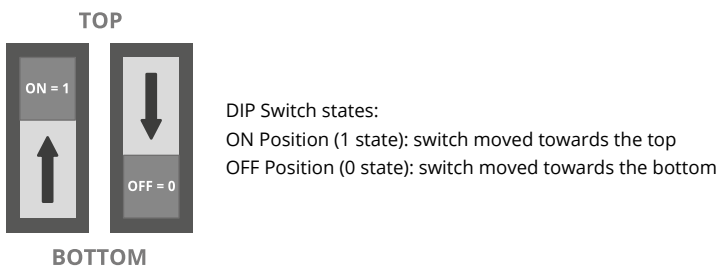

Illustration 4: diagram of internal logic network

The synchronization input is shown at the left as the TRG signal. The synchronization output is shown at the right as the SHT signal. The output activation signal is also shown at the right as the DRV signal.

The four signals TEST, TOFF, OPT0 and OPT1 come from the 4-way dip switch and are used to configure the controller. Their meanings are explained in detail in the following sections. Each of these signals is active (1 state) when its corresponding dip switch is in the ON position (i.e. moved toward the top), while it is inactive (0 state) when its corresponding dip switch is in the OFF position (i.e. moved toward the bottom).

A description of each of the depicted blocks is given in the next sections.



### 9.2. Input filter

The input filter is used to debounce and remove glitches from the incoming synchronization input.

The algorithm implemented in the filter processes the synchronization input with a finite state machine. A change in the filter output is performed only when the input signal has remained constant for a defined period of time, called filter time constant. Any pulses shorter than the filter time constant are thus removed and not passed through.

The following time diagram shows the filter operation on a random input signal.

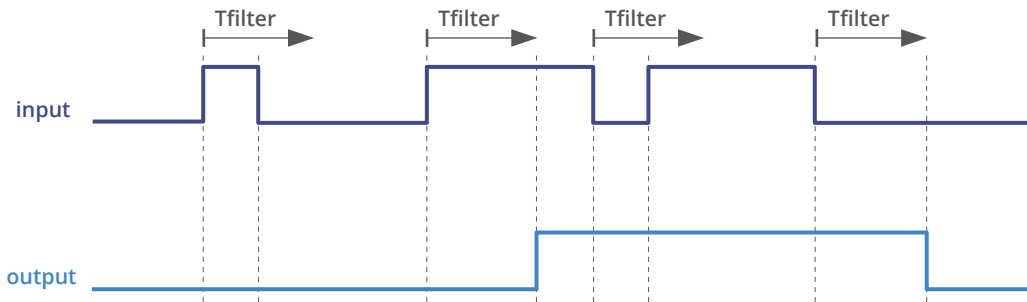

*Illustration 5: operation of the input filter*

As visible, the input signal is filtered by looking for pulses that hold the same state for a time of at least  $T_{filter}$  before the change in state is passed to the output. Please note there is a fixed input to output delay equal to this filter time constant.

Time constant for the input filter can be selected between two values,  $10\mu s$  and  $100\mu s$ . As shown in the internal logic diagram, selection can be made by positioning the OPT0 dip switch. Possibilities are as follows:

- Filtering with a  $10\mu s$  time constant is chosen when  $OPT0 = 0$
- Filtering with a  $100\mu s$  time constant is chosen when  $OPT0 = 1$

### 9.3. Input multiplexer

The input multiplexer is used to select the trigger signal to be sent to the downstream logic. Two sources are available: the filtered synchronization input and the free running oscillator.

The free running oscillator is an autonomous asynchronous source described in detail in the next sections.

As shown in the internal logic diagram, the input multiplexer can be set by positioning the TEST dip switch. Possibilities are as follows:

- Filtered synchronization input is chosen when  $TEST = 0$
- Free running oscillator is chosen when  $TEST = 1$

### 9.4. Output protection

The output protection logic is used to prevent the lighting from getting overheated and thus damaged.

Inside the protection block there is state machine with a couple of timers. The first timer is used to check the activation time ( $T_{on}$ ) of the lighting is short enough (i.e. lesser than or equal to a  $T_{onMAX}$  of 10ms). The second timer is used to check the deactivation time ( $T_{off}$ ) of the lighting is long enough (i.e. greater than or equal to a  $T_{offMIN}$  of 20ms).

The following time diagram shows what happens when both time constraints are satisfied. As visible in the diagram, the output follows the input.

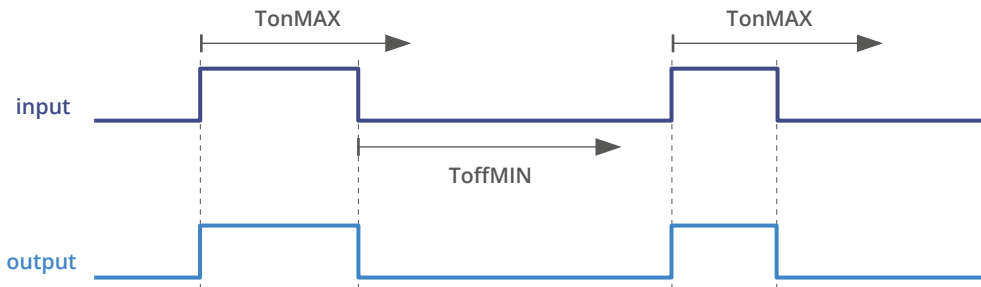

Illustration 6: activation and deactivation times within limits

The following time diagram shows what happens when activation time is too long. As visible in the diagram, the lighting is switched off earlier than required.

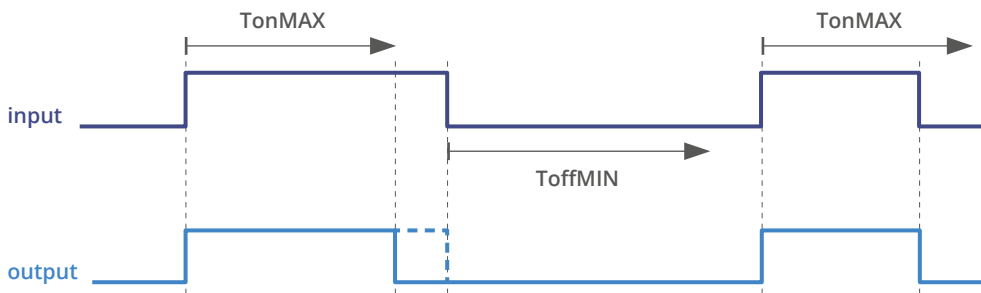

Illustration 7: protection prevents too long activation time

The following time diagram shows what happens when deactivation time is too short. As visible in the diagram, the lighting is turned on later than required.

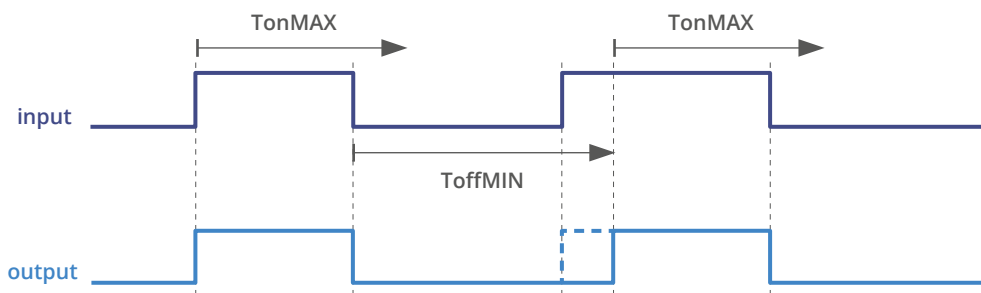

Illustration 8: protection prevents too short deactivation time

The deactivation time check can be disabled if required by the application.

As shown in the internal logic diagram, the deactivation time check can be disabled by positioning the TOFF dip switch. Possibilities are as follows:

- Deactivation time check is enabled when TOFF = 0
- Deactivation time check is disabled when TOFF = 1

### 9.5. Free running oscillator

The free running oscillator is an autonomous asynchronous source with a constant frequency of 5Hz. The pulse generator connected to the oscillator output is used to create short pulses with a width of 500 $\mu$ s.

This train of pulses reaches to the input multiplexer, together with the filtered synchronization input signal, and can be selected as the alternative trigger signal.

Common usage of the oscillator is to test the lighting during assembly and deployment.

### 9.6. Output pulse generator

There is a digital pulse generator fed by the trigger signal coming from the input multiplexer. It is used to produce a well defined output synchronization pulse with a constant width of 10ms.

The output synchronization pulse can be delayed 100 $\mu$ s or can be synchronous to the activation signal, as it is required by the application.

As shown in the internal logic diagram, pulse delay may be chosen by positioning the OPT1 dip switch. Possibilities are as follows:

- A delay of 100 $\mu$ s is implemented when OPT1 = 0
- No delay is implemented when OPT1 = 1

## 10. Wiring diagrams

As discussed in the previous sections the controller is quite flexible and many configurations can be envisioned. The following wiring diagrams describe some of the most common.

### 10.1. Wiring example #1

In the following example schematic the controller is driven by an input trigger, powers a light and triggers a camera.

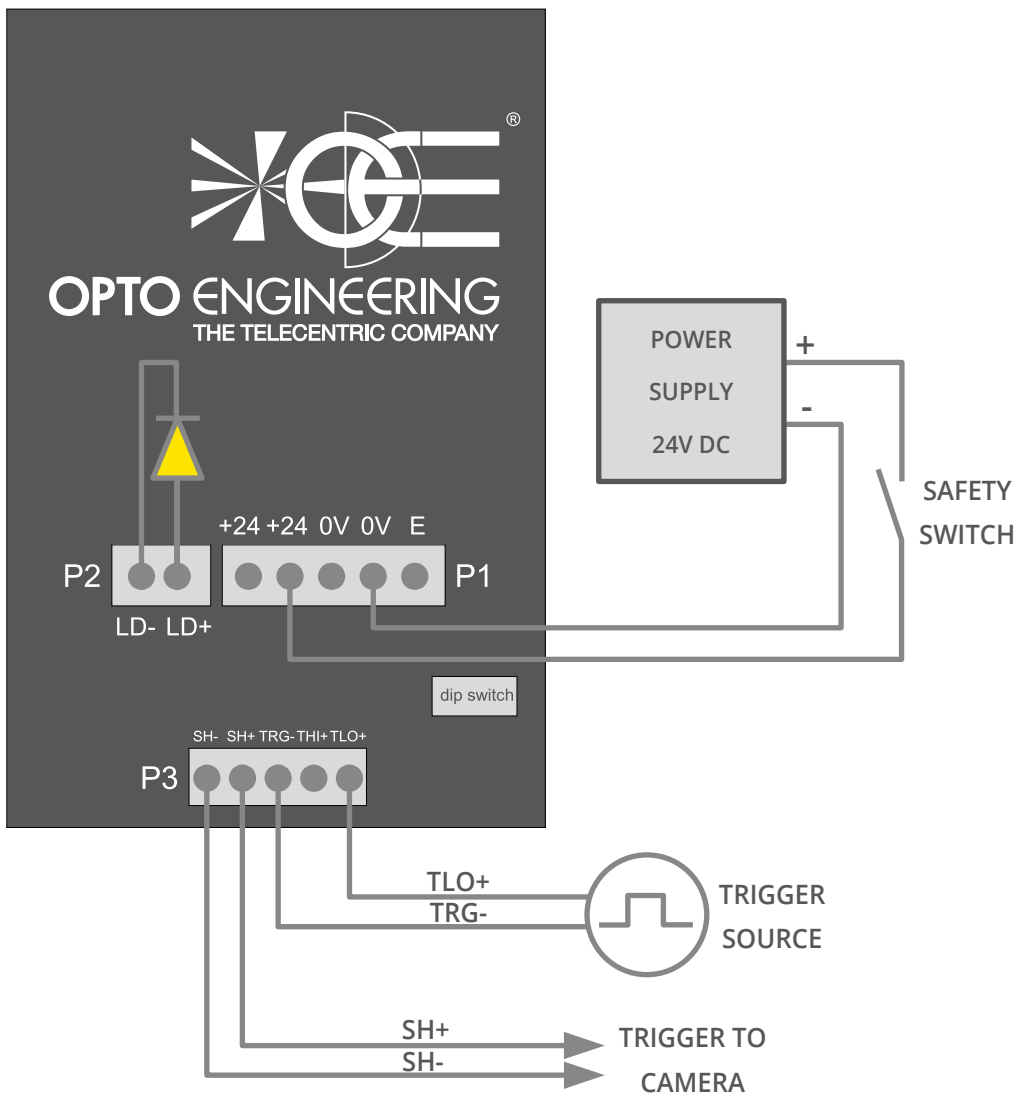

Illustration 9: example schematic #1

As shown the power supply comes from a 24V DC power source.

If required for the application, a safety switch may be included in the circuit to cut off power supply to the controller in order to protect the end user from photo-biological hazard. That switch would be appropriately placed on the machine chassis.

The camera is triggered using the synchronization output. In general it is not possible to provide the details of the connection to the camera because these are often vendor specific. Please see the camera hardware manual for more information.

### 10.2. Wiring example #2

In the following example schematic the camera is driven by an input trigger. The controller is then driven by one of the camera outputs and powers a light. As shown the controller synchronization output is not used.

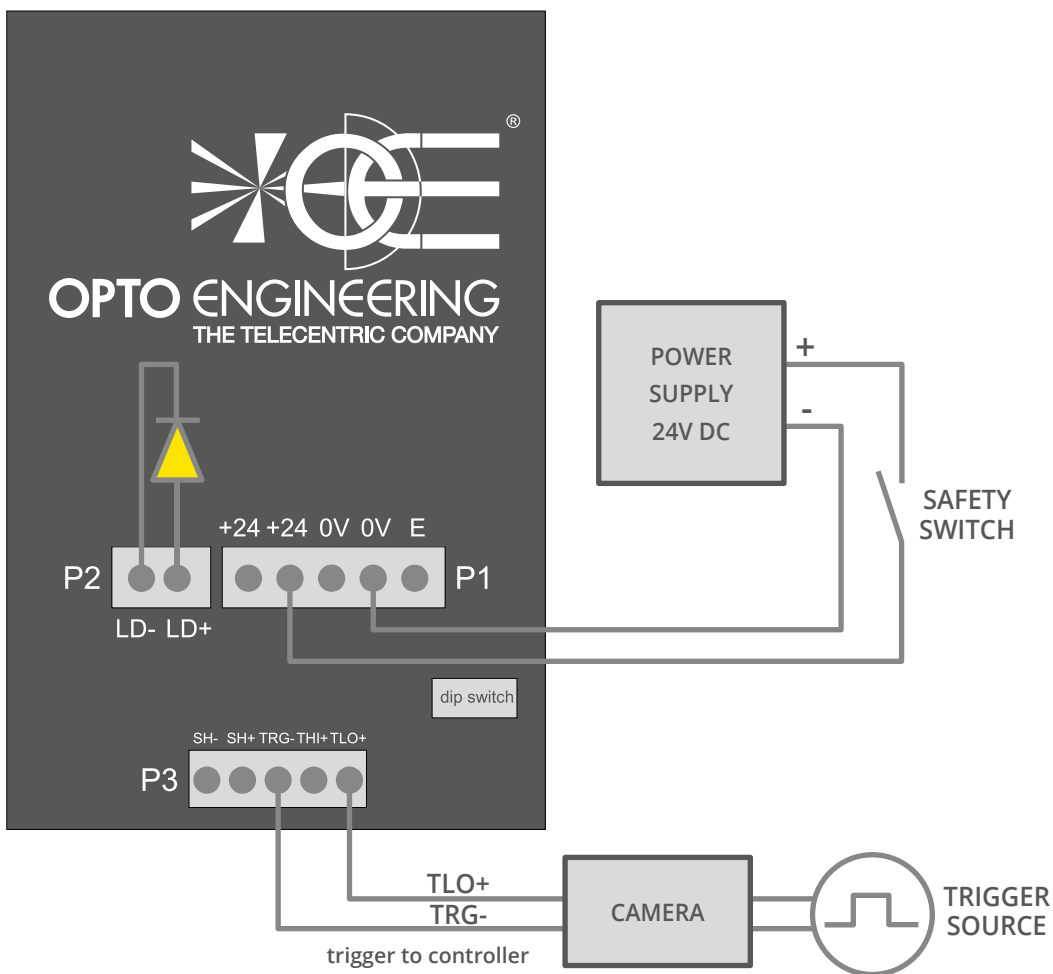

Illustration 10: example schematic #2

As shown the power supply comes from a 24V DC power source.

If required for the application, a safety switch may be included in the circuit to cut off power supply to the controller in order to protect the end user from photo-biological hazard. That switch would be appropriately placed on the machine chassis.

The camera is directly driven by the trigger source and then drives the controller. In general it is not possible to provide the details of the connections to the camera because these are often vendor specific. Please see the camera hardware manual for more information.

## 11. Operation

The controller is set up using the 4-way configuration dip switch in a hollow accessible from the top panel of the controller. The exact meaning of each of the four switches is listed in the following table. Switches are ordered from left to right.

Number	Name	Description
1	TEST	Selects trigger source between synchronization input (when set to OFF) and free running oscillator (when set to ON)
2	TOFF	Enables deactivation time check (when set to OFF) or disables deactivation time check (when set to ON)
3	OPT0	Selects time constant for the synchronization input filter to 10 $\mu$ s (when set to OFF) or 100 $\mu$ s (when set to ON)
4	OPT1	Selects delay for the synchronization output to 100 $\mu$ s (when set to OFF) or no delay at all (when set to ON)

*Table 9: meaning of the dip switches*

These switches should be operated only when the controller is switched off.



## Contact us

### EUROPE

---

**Opto Engineering  
Europe headquarters**

Circonvallazione Sud, 15  
46100 Mantova, IT  
phone: +39 0376 699111  
eu@opto-engineering.com

**Opto Engineering  
Germany**

Agnes-Pockels-Bogen, 1  
80992 München, DE  
phone: +49 0 89 18930918  
de@opto-engineering.com

### UNITED STATES

---

**Opto Engineering  
USA**

11261 Richmond Ave  
Ste G-108 - Houston, TX 77082  
phone: +1 832 2129391  
us@opto-engineering.com

### ASIA

---

**Opto Engineering  
China**

Room 2405, n°885, Renmin RD  
Huangpu District 200010  
Shanghai, China  
phone: +86 21 61356711  
info@deepview.cn

**Opto Engineering  
Japan**

*official partner*  
Optart Corporation  
4-54-5 Kameido Koto-ku  
Tokyo, 136-0071 Japan  
phone: +81-3-5628-5116  
jp@opto-engineering.com

**Opto Engineering  
Korea**

*official partner*  
Far Island Corporation Ltd.  
Seoil Building #703, 353 Sapyeong-daero,  
Seocho-gu, Seoul, Korea 137-810  
phone: +82 70 767 86098  
+82 10 396 86098  
kr@opto-engineering.com